

# PACIFIC SCIENTIFIC N&K-SERIES NEMA 42 HIGH TORQUE MOTORS

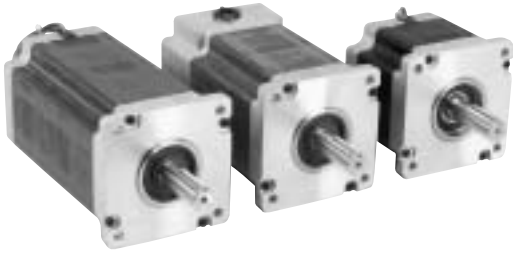

## Features

With holding torques to 5700 oz-in (356 lb-in), the N and K Series provide the highest torques per frame size in the industry— more than 3 and 5 phase designs.

Improved torque linearity (above rated current) provides high peak torque capability (duty cycle dependent, contact factory)

High torque at moderate speeds

Low detent torque harmonic

K Series uses patented Sigmax® technology to develop 25% more torque than N Series

Runs cooler than comparable steppers using identical drive parameters

Special rotor design for high acceleration

Rugged "housingless" square frame

Sealed per IP65

Outer bearing races won't turn— front locked (in steel insert) and rear held by O-ring

Extensive selection of shaft configurations, terminations, standard and special windings

Two phase design

Optional encoder mounting provisions

## Benefits

Optimized magnetics provide maximum performance in small envelope, reducing space required for the motor.

Acceleration boost to move loads even faster. Provides more torque for intermittent duty applications.

Cost effective alternative to servo motors

Provides smoother microstepping performance

Select from broad performance range to meet your requirement

Longer, more reliable motor life— backed by a two year warranty

Move/position loads fast

Efficient use of volume for optimal magnetic circuit

For splashproof requirements

Long life bearings— also prevents axial shaft movement for encoder applications

Match your requirements

Compatible with most drivers, smoother microstepping, and lower input power required vs. three phase for same torque

Optimizes control scheme

## LEADWIRE HOOKUP MODELS

(mm) in

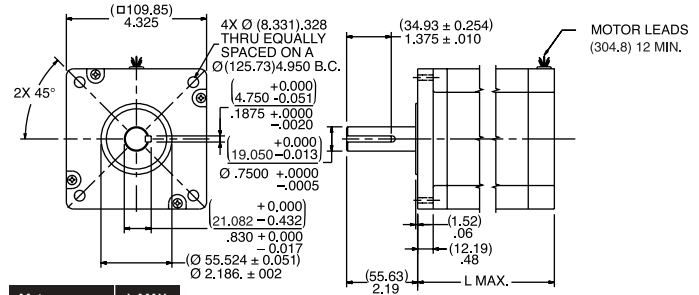

Motor	L MAX
41xx	(98.81) 3.89
42xx	(150.11) 5.91
43xx	(201.17) 7.92

① Motor leads 12.0 Min.

## SPLASHPROOF CONSTRUCTION-TERMINAL BOARD CONNECTIONS

(mm) in

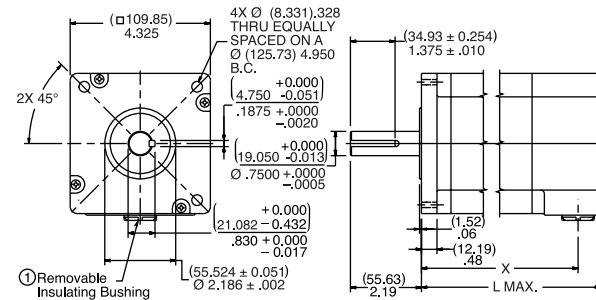

Motor	X	L MAX
41xx	(113.28) 4.46	(132.08) 5.20
42xx	(164.59) 6.48	(183.39) 7.22
43xx	(215.65) 8.49	(234.44) 9.23

## SPLASHPROOF CONSTRUCTION-MS CONNECTOR(S)

(mm) in

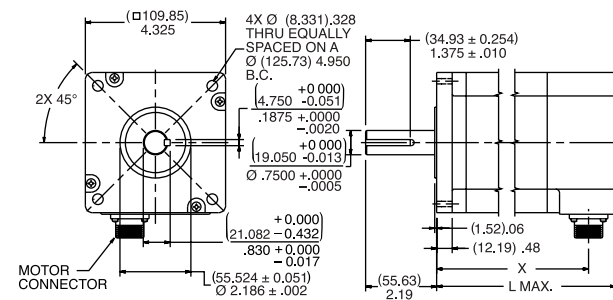

Motor	X	L MAX
41xx	(109.73) 4.32	(132.08) 5.20
42xx	(160.78) 6.33	(183.39) 7.22
43xx	(212.09) 8.35	(234.44) 9.23

# PACIFIC SCIENTIFIC N&K-SERIES NEMA 42 HIGH TORQUE MOTORS

## RATINGS AND CHARACTERISTICS SEE SYSTEM RECOMMENDATIONS AND DATA ON PAGE 93.

Motor parameters and winding data.

Typical Leadwire Motor Model Number	Connection <sup>①</sup>			Holding Torque <sup>②</sup> (2 phases on) oz-in (N-m) ±10%	Rated Current/Phase <sup>③</sup> (amps DC)	Phase Resistance (ohms) ±10%	Phase Inductance <sup>④</sup> (mH) Typical	Detent Torque oz-in (N-m)	Thermal Resistance <sup>⑤</sup> (°C/watt)	Rotor Inertia oz-in-S <sup>2</sup> (kgm <sup>2</sup> x 10 <sup>-3</sup> )	Net Weight kg (lbs)
	Parallel	Series	Unipolar								
<b>K SERIES - SIGMAX<sup>®</sup> 1 ROTOR STACK</b>											
K41HRFM-LNK-NS-00	●			2135 (15.07)	10.7	0.16	2.2	65 (0.46)	1.9	0.0783 (0.55)	4.98 (11)
K41HRFM-LNK-NS-00		●		2135 (15.07)	5.3	0.63	8.7				
K41HRFM-LNK-NS-00			●	1510 (10.66)	7.5	0.31	2.2				
K41HRFL-LNK-NS-00	●			2090 (14.75)	8.7	0.23	3.1				
K41HRFL-LNK-NS-00		●		2090 (14.75)	4.4	0.93	12.3				
K41HRFL-LNK-NS-00			●	1480 (10.45)	6.2	0.47	3.1				
<b>N SERIES - Standard 1 ROTOR STACK</b>											
N41HRFM-LNK-NS-00	●			1655 (11.68)	10.7	0.16	2.8	42 (0.30)	1.9	0.0783 (0.55)	4.98 (11)
N41HRFM-LNK-NS-00		●		1655 (11.68)	5.3	0.63	11.1				
N41HRFM-LNK-NS-00			●	1170 (8.26)	7.5	0.31	2.8				
N41HRFL-LNK-NS-00	●			1625 (11.47)	8.7	0.23	3.9				
N41HRFL-LNK-NS-00		●		1625 (11.47)	4.4	0.93	15.8				
N41HRFL-LNK-NS-00			●	1150 (8.12)	6.2	0.47	3.9				
<b>K SERIES - SIGMAX<sup>®</sup> 2 ROTOR STACK</b>											
K42HRFM-LNK-NS-00	●			4000 (28.23)	15.8	0.1	1.6	126 (0.89)	1.3	0.1546 (1.09)	8.34 (18.4)
K42HRFM-LNK-NS-00		●		4000 (28.23)	7.9	0.41	6.5				
K42HRFM-LNK-NS-00			●	2830 (19.97)	11.2	0.21	1.6				
K42HRFM-LNK-NS-00	●			4025 (28.41)	9.9	0.25	4.2				
K42HRFM-LNK-NS-00		●		4025 (28.41)	4.9	1.02	16.9				
K42HRFM-LNK-NS-00			●	2845 (20.08)	7	0.51	4.2				
<b>N SERIES - Standard 2 ROTOR STACK</b>											
N42HRFM-LNK-NS-00	●			3130 (22.09)	15.8	0.1	2.1	84 (0.59)	1.3	0.1546 (1.09)	8.34 (18.4)
N42HRFM-LNK-NS-00		●		3130 (22.09)	7.9	0.41	8.4				
N42HRFM-LNK-NS-00			●	2215 (15.63)	11.2	0.21	2.1				
N42HRFM-LNK-NS-00	●			3145 (22.20)	9.9	0.25	5.5				
N42HRFM-LNK-NS-00		●		3145 (22.20)	4.9	1.02	22				
N42HRFM-LNK-NS-00			●	2225 (15.70)	7	0.51	5.5				
<b>K SERIES - SIGMAX<sup>®</sup> 3 ROTOR STACK</b>											
K43HRFM-LNK-NS-00	●			5700 (40.23)	15.4	0.14	2.5	118 (0.83)	1	0.2293 (1.62)	11.64 (25.7)
K43HRFM-LNK-NS-00		●		5700 (40.23)	7.7	0.55	10				
K43HRFM-LNK-NS-00			●	4030 (28.44)	10.9	0.28	2.5				
K43HRFM-LNK-NS-00	●			5630 (39.74)	9.9	0.33	5.9				
K43HRFM-LNK-NS-00		●		5630 (39.74)	4.9	1.32	23.7				
K43HRFM-LNK-NS-00			●	3985 (28.13)	7	0.66	5.9				
<b>N SERIES - Standard 3 ROTOR STACK</b>											
N43HRFM-LNK-NS-00	●			4365 (30.81)	15.4	0.14	3.2	106 (0.75)	1	0.2293 (1.62)	11.64 (25.7)
N43HRFM-LNK-NS-00		●		4365 (30.81)	7.7	0.55	13				
N43HRFM-LNK-NS-00			●	3090 (21.81)	10.9	0.28	3.2				
N43HRFM-LNK-NS-00	●			4320 (30.49)	9.9	0.33	7.7				
N43HRFM-LNK-NS-00		●		4320 (30.49)	4.9	1.32	30.7				
N43HRFM-LNK-NS-00			●	3055 (21.56)	7	0.66	7.7				

All ratings typical and at 25°C unless otherwise noted.

① Refer to Selection Guide for more information.

② With rated current applied.

③ Windings at 130°C and motor in still air at 40°C (without heat sink). Operation of these motors above rated current may cause demagnetization. Contact factory.

④ Small signal inductance as measured with impedance bridge at 1 kHz, 1 amp.

⑤ Thermal resistance measured with motor hanging in still air (unmounted).



### MOTIONEERING<sup>®</sup> CD-ROM

For more detailed product and selection information, see the MOTIONEERING CD-ROM inside the back cover of this catalog or visit our website at [www.DanaherMotion.com](http://www.DanaherMotion.com).

# PACIFIC SCIENTIFIC N&K-SERIES NEMA 42 STEPPER SYSTEMS

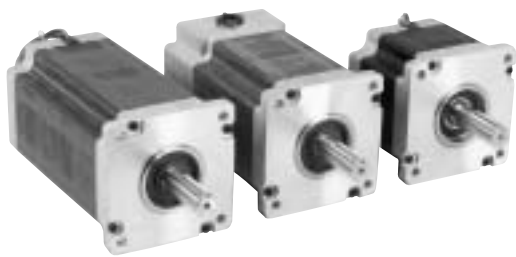

The performance information shown in the torque/speed curves that follow show the N & K series of NEMA 42 step motors with windings, connections and current levels selected for maximum performance with the drives shown on this page. For additional assistance in sizing or selecting the stepper system appropriate for your application, contact Danaher Motion Customer Support at 815-226-2222.

## PACIFIC SCIENTIFIC N&K-SERIES NEMA 42 STEPPER SYSTEMS



### 6410/6415 Microstepping Drives SEE PAGE 72

- 24-75 VDC input
- Step/direction input or oscillator models
- Current selectable from 0.625 to 7.1 amps peak
- Selectable step sizes, binary or decimal, full to 1/250 or 1/256



### Impulse Microstepping Drives SEE PAGE 75

- 90-120 VAC input, 160 VDC bus
- Step/direction input
- Programmable inputs/outputs
- Current selectable from 0.75 to 4.0 amps
- Microstepping 200 to 100,000, selectable in increments of 200



### NextStep® Microstepping Drives SEE PAGE 76

- 90-120 VAC input, 160 VDC bus. 240 V model available
- Step/direction input
- Current selectable from 0 to 7.9 amps, to 3.9 A for 240 V model
- 5,000 steps/rev to 50,000 steps/rev microstepping



### SMARTSTEP Microstepping Drives SEE PAGE 77

- 90-120 VAC input, 160 VDC bus. 240 V model available
- Programmable indexing
- Current selectable from 0 to 7.9 amps, to 3.9 A for 240 V model
- 36,000 steps/rev microstepping

# PACIFIC SCIENTIFIC N&K-SERIES NEMA 42 STEPPER SYSTEMS

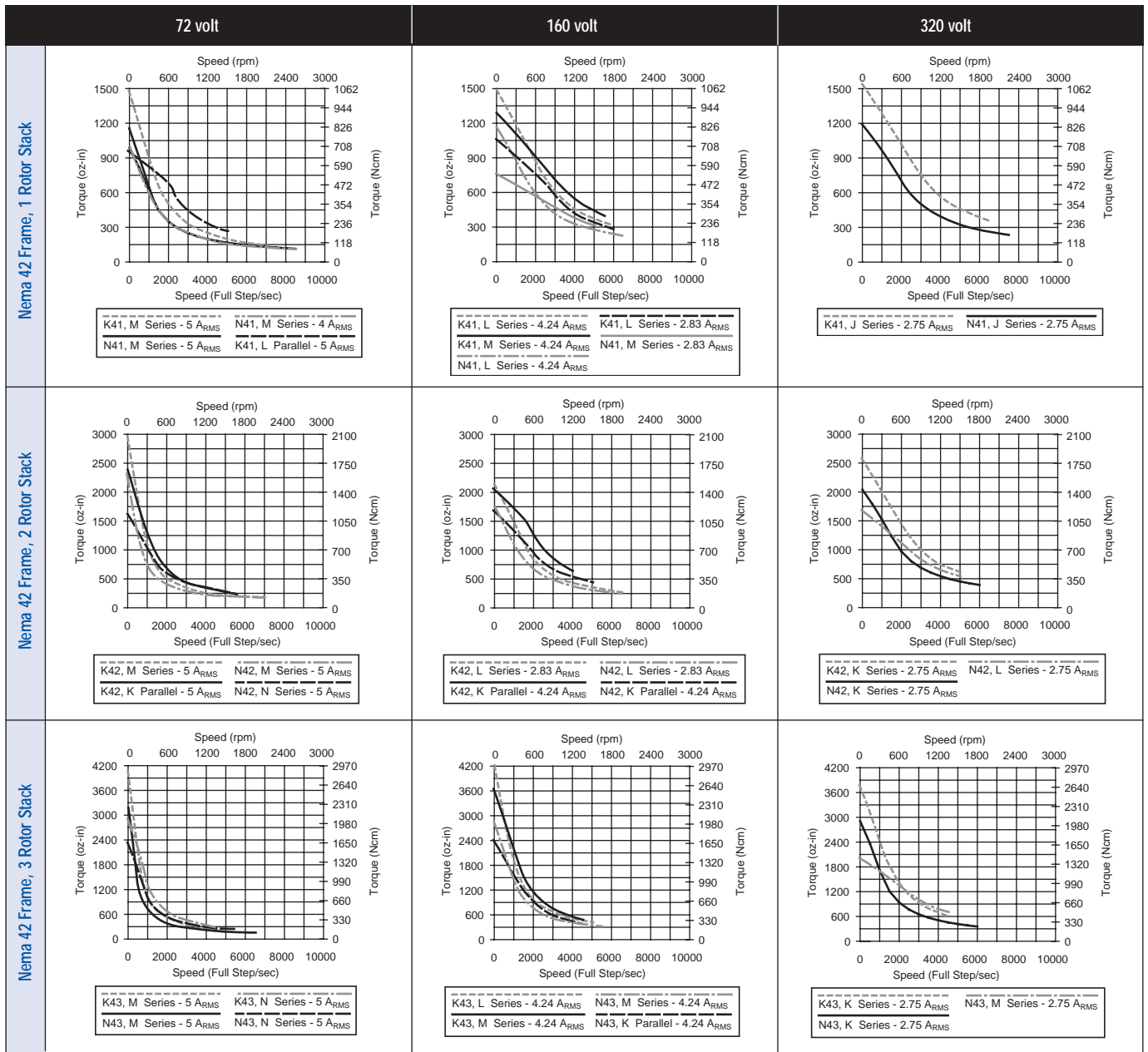

## MOTIONEERING® CD-ROM

For more detailed product and selection information, see the MOTIONEERING CD-ROM inside the back cover of this catalog or visit our website at [www.DanaherMotion.com](http://www.DanaherMotion.com).